

Data Sheet

80 Wafer Isolation Ring

FEATURES

- 360° Instrument rotation with SQR™ option
- Selection of 2" through 20" nominal pipe size
- Non-clogging/low maintenance
- Complete instrument protection
- Ensure reliable/accurate pressure readings
- Optional retrofit end plates to replace competitive units
- NSF-61 Compliant (316L Stainless steel/EPDM only)

TYPICAL USES

- Water and wastewater
- Mining

SPECIFICATIONS

Sizes:	2" to 20"
Instrument Connection Size:	¼, ½ NPT
Pressure Rating (MAWP):	Per customer flanges: ASME B16.5 150 or 300 class
Fill:	Glycerin: 0 °F to 400 °F (-18 °C to 204 °C) Silicone (10Cst): -40 °F to 500 °F (-40 °C to 260 °C) Silicone (50Cst): -40 °F to 600 °F (-40 °C to 316 °C) Halocarbon®: -70 °F to 300 °F (-57 °C to 149 °C)
Instrument Options:	Direct-mount, Needle valve, Safe Quick Release (SQR™), Needle valve and SQR™ (02T conn.)
Added Tolerance:	±0.5% typical
Approvals:	CRN, NSF-61 (316L Stainless steel / EPDM only)

WETTED COMPONENTS

End Plate Material	Flexible Liner
Carbon steel, 316L Stainless steel, PVDF, Acetal, CPVC	Buna, PTFE, EPDM, Natural rubber, and Viton™

NON-WETTED COMPONENTS

Body	Instrument Fittings
Carbon Steel, 316L Stainless steel	Adapters: 316L Stainless steel Needle Valve: 316L Stainless steel SQR: Zinc-plated carbon steel

MIN/MAX TEMPERATURE LIMITS

Liner	Temperature Limits
Buna-N	-30 °F to 225 °F (-34 °C to 107 °C)
PTFE	-15 °F to 350 °F (-25 °C to 177 °C)
Viton™	-15 °F to 350 °F (-25 °C to 177 °C)
Natural Rubber	-30 °F to 225 °F (-34 °C to 107 °C)
EPDM	-40 °F to 300 °F (-40 °C to 149 °C)



80 Wafer Isolation Ring

Nominal Size: 2" to 20"



Certified to
NSF/ANSI/CAN 61

KEY BENEFITS

- Reliable when continuous pressure measurements are needed
- Non-clogging and low maintenance
- Complete instrument protection

80 Wafer Isolation Ring

ORDERING CODE	Example:	80	02	E	B	B	02T	N	000	XCK	H3	NH
Seal Type												
80 - Wafer style isolation ring		80										
Process Connection Size												
02 - 2" (see table 2 on page 3)			02									
Inner Flexible Wall												
E - Buna-N				E								
T - PTFE (available in 2" to 10")												
Y - Viton™												
R - Natural rubber												
P - EPDM (NSF-61 Compliant)												
End Plate Material												
A - Acetal												
K - CPVC												
B - Carbon steel					B							
S - 316L Stainless steel (NSF-61 Compliant)												
F - PVDF												
Body Material												
B - Carbon steel						B						
S - 316L Stainless steel												
Instrument Connection Size												
02T - ¼ NPT Female							02T					
04T - ½ NPT Female (ring body tapped with ¼ NPT connection; 04T connection utilizes ¼-½ NPT adapter)												
Instrument Removal Option												
N - Direct-mount (2" to 8")								N				
V - Needle valve (2" to 8")												
Q - Safe Quick Release (SQR™)												
Z - Needle valve and SQR												
Pressure Class												
000 - Wafer design									000			
Options (if choosing option(s) must include an "X")										X__		
Fill Fluid (see table 3 on page 3 for more available fill fluids)												
CG - Glycerin												
CK - Silicone 50cSt										CK		
CF - Halocarbon®												
CT - 50/50 Ethylene Glycol/water												
Multiple Instrument Assemblies (contact factory for additional arrangements or custom orientations.)												
H3 - ¼ NPT gauge/ ¼ NPT transducer/ 02T isolation ring											H3	
H5 - ½ NPT gauge/ ½ NPT switch/ 04T isolation ring												
H6 - ½ NPT gauge/2 ½ NPT switches/ 02T isolation ring												
H7 - ¼ NPT gauge/ ¼ NPT switch/ 02T isolation ring												
Refer to Assembly Guide for additional assembly options												
Optional Features												
IR - Retrofit end plates (custom end plate widths for drop-in replacements)												
NH - Stainless steel tag wired to ring											NH	
Q8 - Elbow for vertical pipe installation												

When selecting an instrument, refer to the [Diaphragm Seal Pressure & Temperature Min/Max Guide](#) for compatibility with this isolation ring or scan the QR code to the right.



All specifications are subject to change without notice. All sales subject to standard terms and conditions. Ashcroft®, Safe Quick Release (SQR)™ and Trust the Shield® are trademarks of Ashcroft Inc. The following non-Ashcroft trademarks are the property of their respective owners: Halocarbon® and Viton™. For more information, see [Ashcroft Brands & Trademarks](#). ©2024 Ashcroft Inc. 80_wafer_iso_ring_ds_RevG_08-30-24

80 Wafer Isolation Ring

TABLE 2 – PROCESS CONNECTION TABLE

Process Connection Code (Nominal Size)	Type 80 (Ordering Code)
2"	02
3"	03
4"	04
5"	05
6"	06
8"	08
10"	10
12"	12
14"	14
16"	16
18"	18
20"	20

Consult factory for larger sizes

DIMENSIONS

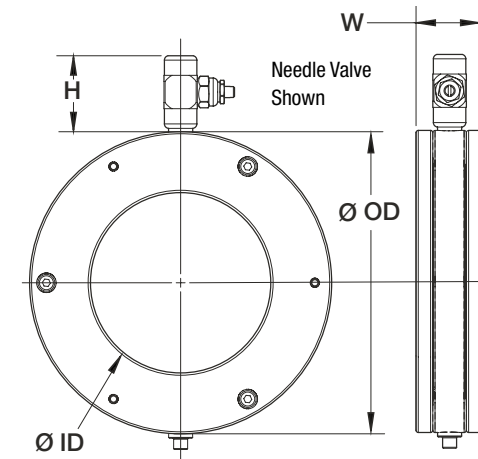

Nominal Pipe Size Inches	Inner Diameter (ID)	Outer Diameter (OD)	Width (W) Metallic Endplates	Width (W) Non Metallic Endplates	Width (W) XIR Endplates	H			Weight Lbs. (metal end plates)
						Direct	Safe Quick Release	Needle Valve	
2	2.07	4.00	2.00	2.13	2.13	1.89	2.04	1.70	4.00
3	3.07	5.25	2.00	2.13	2.13	1.89	2.04	1.70	6.30
4	4.03	6.75	1.50	2.13	2.13	1.89	2.04	1.70	8.00
5	5.05	7.63	1.50	2.25	2.25	1.89	2.04	1.70	9.50
6	6.07	8.63	1.50	2.25	2.25	1.89	2.67	2.32	10.20
8	7.98	10.88	1.50	2.50	2.50	2.39	2.67	2.32	14.90
10	10.02	13.25	1.50	2.75	2.75	2.39	2.67	2.32	21.30
12	12.00	16.00	1.75	3.00	3.00	2.39	2.67	2.32	39.10
14	13.25	17.63	1.75	3.00	3.00	2.89	3.17	2.82	47.80
16	15.25	20.13	1.75	3.00	3.00	2.89	3.17	2.82	58.00
18	17.25	21.50	1.75	3.00	3.00	2.89	3.67	3.32	61.80
20	19.25	23.75	1.75	3.00	3.00	2.89	3.67	3.32	68.80

All specifications are subject to change without notice. All sales subject to standard terms and conditions. Ashcroft®, Safe Quick Release (SQR)™ and Trust the Shield® are trademarks of Ashcroft Inc. The following non-Ashcroft trademarks are the property of their respective owners: Halocarbon® and Viton™. For more information, see [Ashcroft Brands & Trademarks](#). ©2024 Ashcroft Inc. 80_wafer_iso_ring_ds_RevG_08-30-24